

PARKING LIGHT WIRE - (2000-2005 IMPALA AND MONTE CARLO)



NOTE:

On 2000-Up Chevy Impalas and Monte Carlos, the parking light wire must be isolated from the BCM to avoid the "Service Engine Soon" light from coming on. Cut the wire and

► Use a relay and wire as shown:

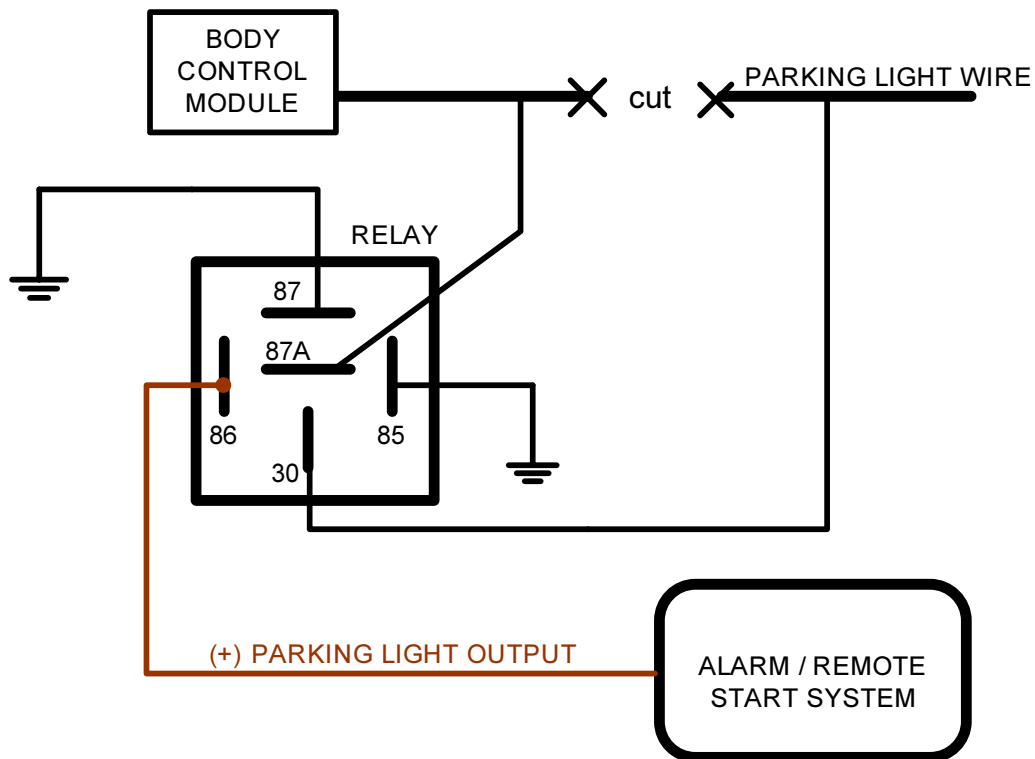

PIN	CONNECTION
85	TO CHASSIS GROUND
86	TO (+) PARKING LIGHT OUTPUT FROM ALARM/REMOTE START SYSTEM
87	TO CHASSIS GROUND
87A	TO PARKING LIGHT WIRE – SWITCH SIDE
30	TO PARKING LIGHT WIRE – LIGHT SIDE

Remote starter and security installations should be attempted by experienced security installers only. Information contained is accurate to the best of our knowledge and experience. Information contained is without any representation of warranty. It is the installer's responsibility to test and confirm all circuits with a digital multi-meter. Proper installation remains the responsibility of the installer. CarInstallExperts.com assumes no liability or responsibility resulting from an improper installation, even in reliance with the information contained in this guide.